



What to Improve First?

Use of an Enterprise Benefits Model

Presented to the IoQNZ 2005 Conference

Terry Shannon Spire Consulting





Where do you Start?

- Must focus on ultimate business goal
 - To make money now, and to make more money in the future
- What are the measures;
 - Net Profit
 - Return on Investment

These ones certainly get the attention of the Owner/CEO/GM!



What do you need?

- What if you could relate physical performance to these financial measures?
- What about being able to do “What ifs” around the table with your team?
- How about something like this?



A Prototype

Relationships between Operations and Financial Wellbeing

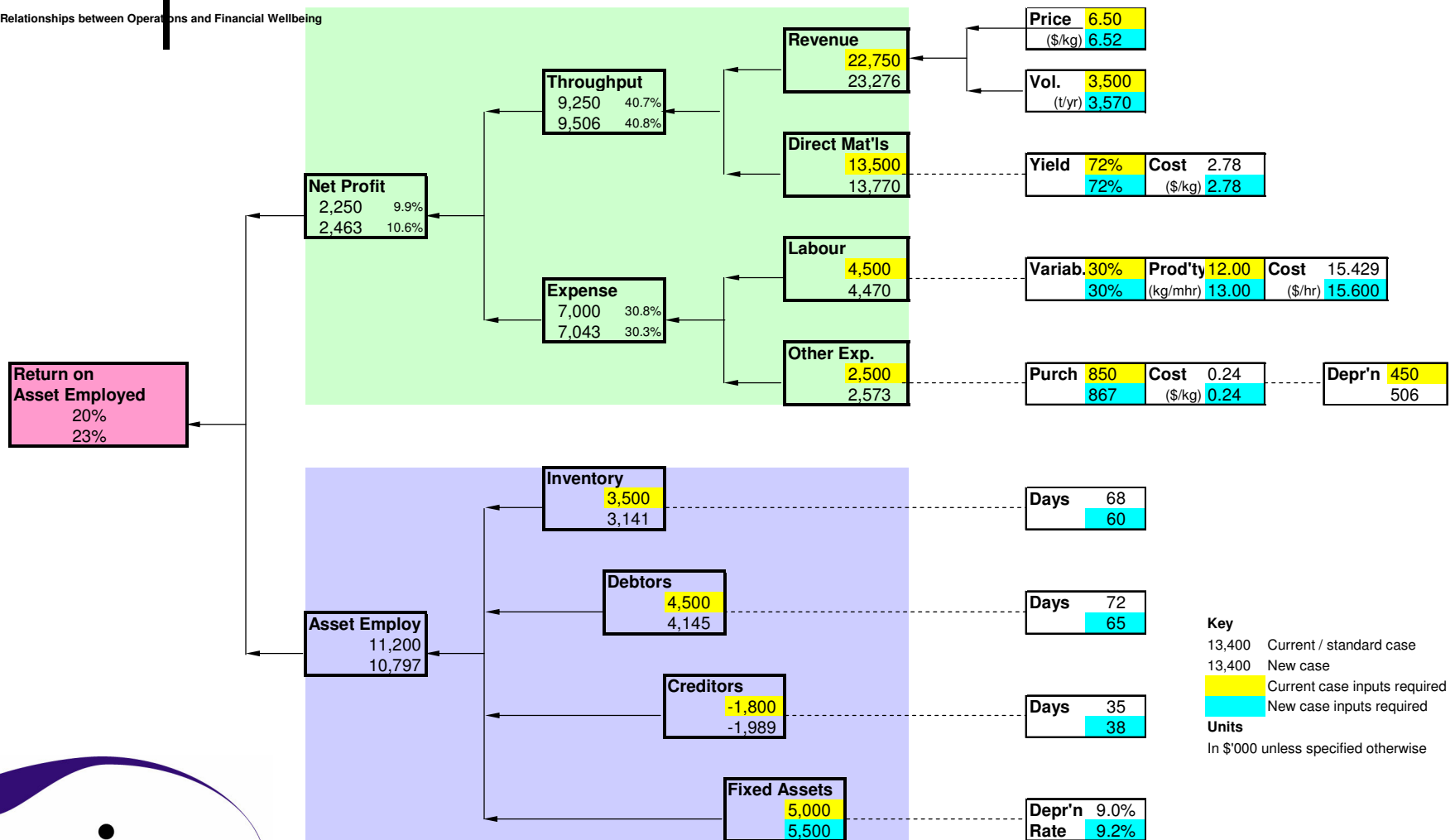



The Principles:-

- Optimisation - A big word for
 - “doing things better; getting more for less”
- Concerned about improving the outputs
 - Usually by altering a process or an input
 - Implies utilising what you have got
- Basic principle

The overall optimum is not usually the total of each component being optimum
- Must take into account the **whole** operation



How do you get to the Cause?

Financial Performance - Cause and Effect
Relationships between Operations and Financial Wellbeing

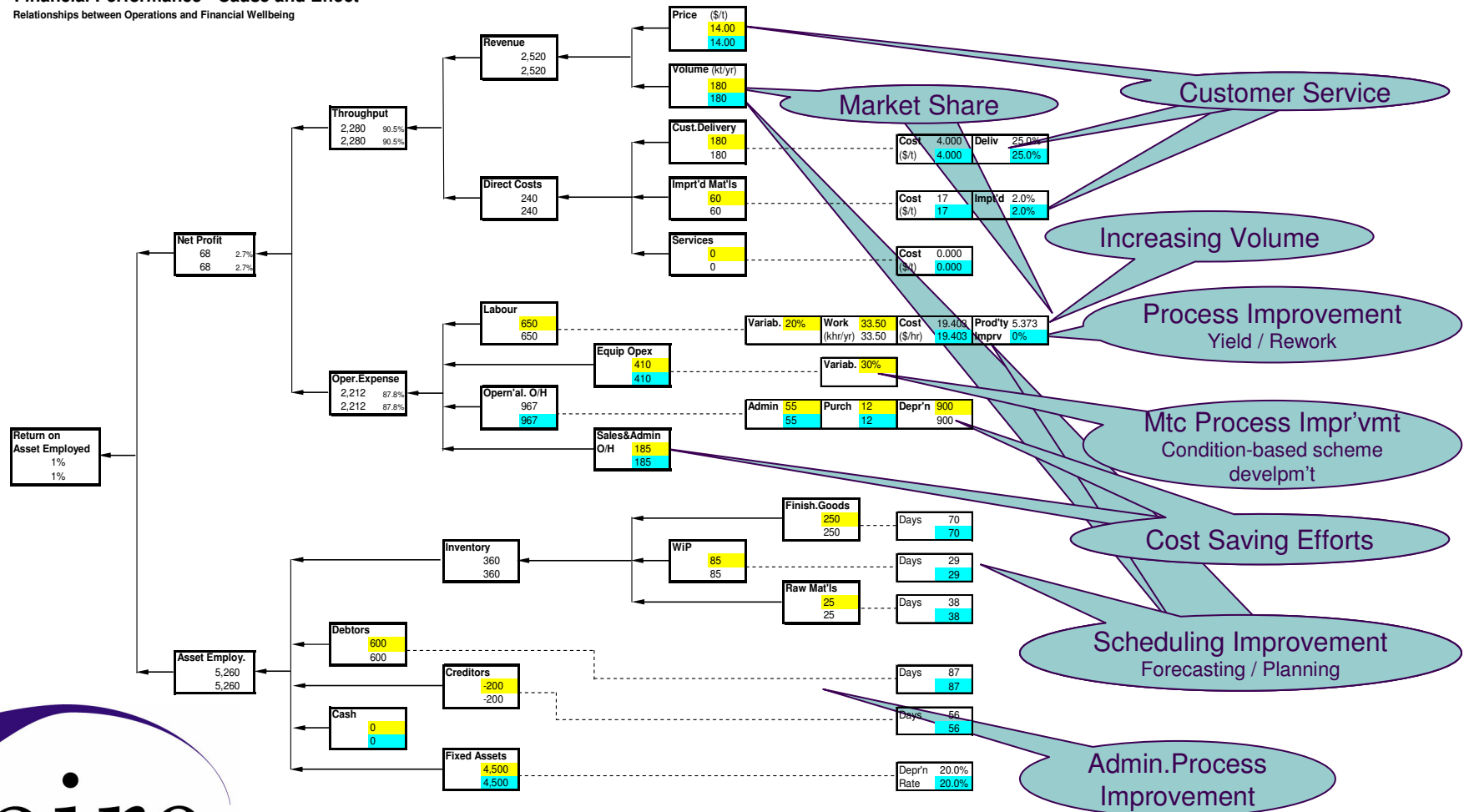

Cause and Effect – the Demming Chain Reaction

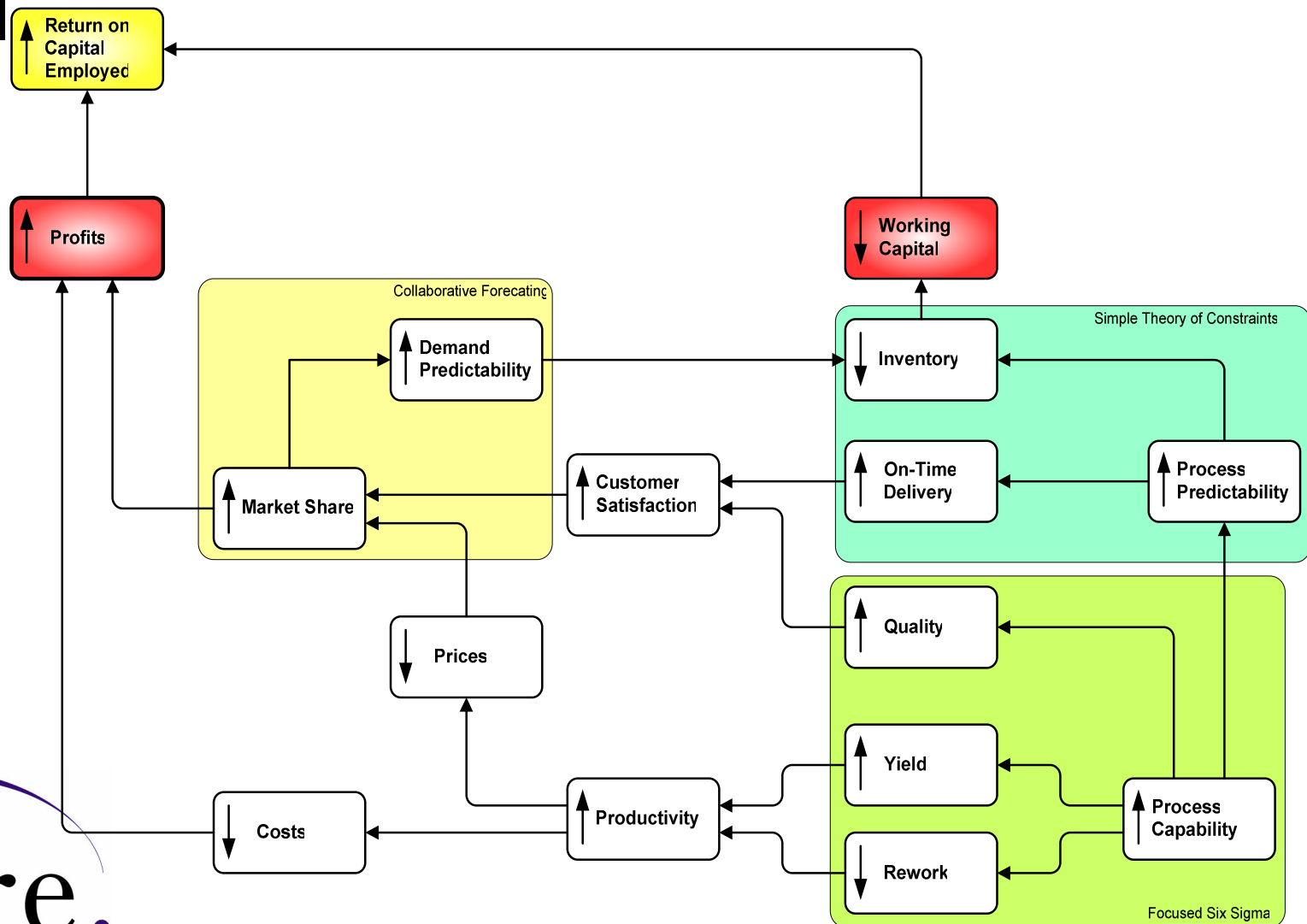



Summary

- A simple technique to assign priorities
- To promote consensus decisions
- To quantify project objectives
- To lead to actions to achieve the benefits
- Any Questions?

Thank you